

PRECISION

SAWMILL SERIES
VIBRATING CONVEYOR



Engineered for Performance, Built for Endurance

P.O. Drawer 507 • Leeds, Alabama 35094 • Phone (205) 640-5181 • Fax (205) 640-1147 • Email: sales@precisionhusky.com

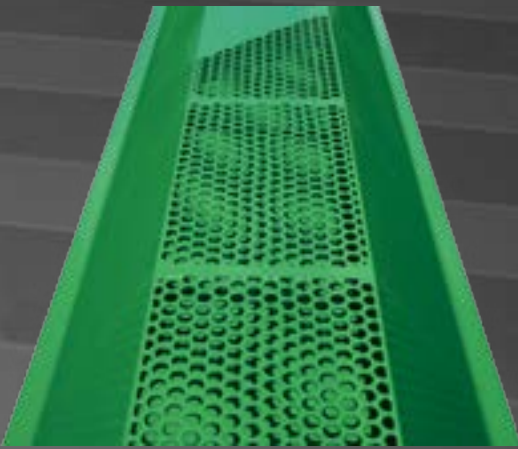

Sawdust removal screen allows only blocks, slabs and edgings to enter the chipper, increasing chipper blade effectiveness and reducing dust. Sawdust discharge is custom and user specified.



Vibrating Table

All components are heavy-duty as the spherical roller bearings used in the drive section. Motor under the conveyor gives added protection. Contact the factory for custom sizes, vibrating tables, various custom widths and screening sizes. Options include: chipper transitions, fiberglass sections for metal detector use, sawdust drop outs and wear liners.



Main frame for the heavy-duty unit is made from 6" channel at 16.3 pounds per foot. The vibrating conveyor's energy is transferred through the heavy-duty fiberglass support bars to the heavy-duty channel. This secure footing reduces maintenance and insures long life.

Specifications given were approved at the time of initial printing and are subject to change without notice and without incurring any liability.

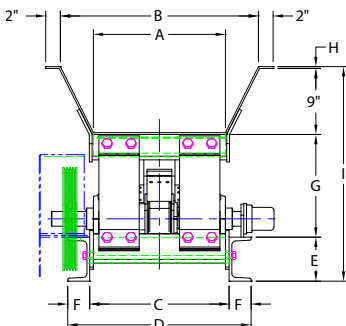

PMD MEDIUM-DUTY								
A	B	C	D	E	F	G	H	I
18" [457mm]	27" [686mm]	15.5" [394mm]	19 1/4" [489mm]	5" [127mm]	1 7/8" [48mm]	7 3/4" [197mm]	3/16" [5mm]	21 3/4" [552mm]
24" [610mm]	33" [838mm]	15.5" [394mm]	19 1/4" [489mm]	5" [127mm]	1 7/8" [48mm]	7 3/4" [197mm]	3/16" [5mm]	21 3/4" [552mm]

PHD HEAVY-DUTY								
A	B	C	D	E	F	G	H	I
18" [457mm]	27" [686mm]	19" [483mm]	25" [635mm]	6" [152mm]	3" [76mm]	14" [356mm]	1/4" [6mm]	29" [737mm]
24" [610mm]	33" [838mm]	19" [483mm]	25" [635mm]	6" [152mm]	3" [76mm]	14" [356mm]	1/4" [6mm]	29" [737mm]